

△ OPEN-DECK CONSTRUCTION

TRAIL KING



TKSA

HYDRAULIC SLIDING AXLE

LOOKING FOR MORE?

Navigate to www.trailking.com, and click on the SOLUTIONS tab. Each product page includes specifications, video, literature, images, services information and our official color card.



Apitong Decking



STANDARD FEATURES



Front Access Panel

Standard front access panel offers easy access for connecting hydraulic, air and electrical lines. The panel may also be opened for internal maintenance or repair simply by removing four bolts.



Winch

Even disabled equipment can be loaded with ease with the 20,000-lb. winch and 9/16" cable, which comes standard with winch guard and 80' cable with locking safety hook. Optional fair lead roller available.



Hydraulic Valve Controls

Dual-side push/pull, lighted hydraulic controls and Kar-Tech remote are standard (winch only). Optional full function remote (shown) offers 2-speed operation. Slow-speed function decreases speed by 50% to allow for better maneuverability of tricky equipment.



Toolboxes

Two side-access toolboxes at front of upper deck with chrome T-handles are standard. (Top access with gas shock and lights are popular options.)

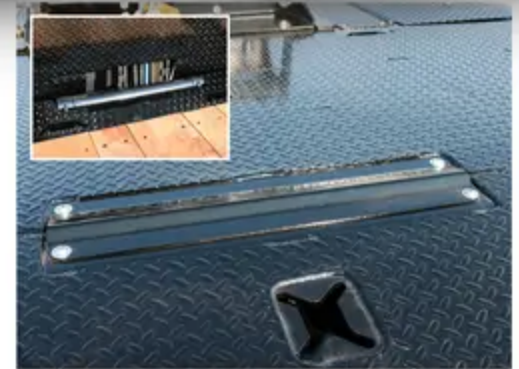

Winch Roller & Skid Plate

A recessed roller at the front of the main deck and a skid plate on the slope of the upper deck are standard. They protect both the winch cable and the deck of the trailer from damage during loading and unloading. A second roller in lieu of the skid plate is optional.



Perimeter Frame Design

The perimeter frame delivers maximum strength and stability during loading and unloading. The design also includes a track system to protect air lines when the trailer is in the transport position.

TRAIL KING SLIDING AXLE

LOW LOAD ANGLE LOW MAINTENANCE FASTEST IN THE INDUSTRY

It's the FASTEST Sliding Axle in the industry, cycling from transport to loading and back in only 61 seconds! Engineered for speed, this trailer also offers easier maintenance, an increased swing clearance and more usable deck length. The TKSA features a low load angle, additional corrosion protection and a smoother, precise operation. Time is money, and this trailer will save you both!

Popular Options

- Top access toolbox with gas shocks & lighting
- Fair lead roller
- Full Function Remote
- Second winch roller
- Stake pockets



Find your nearest rep: www.TrailKing.com/find-a-rep

#LOOKFORTHETRIANGLES



@trailkingind

Faster Sliding Function

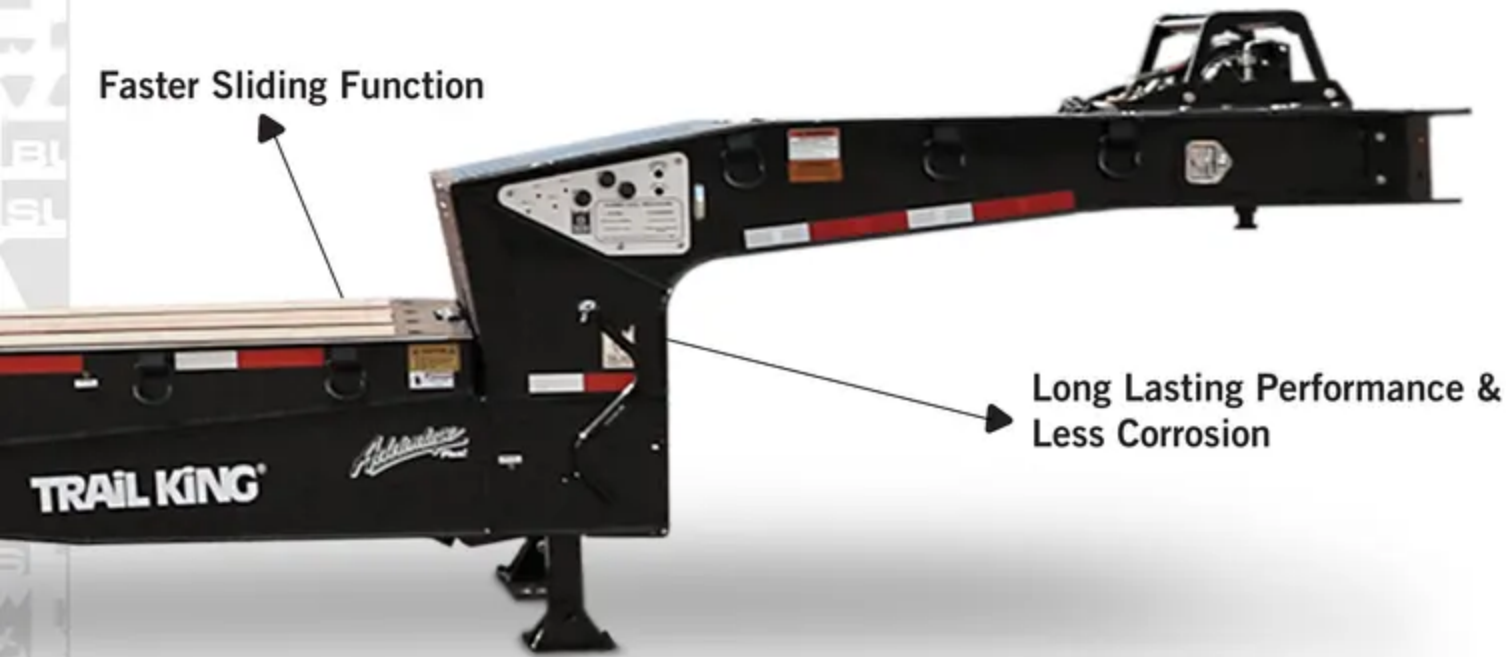

Long Lasting Performance & Less Corrosion



Slide Pan & 2-Stage Cylinder

This hydraulic system has been designed for speed. Open slide pan reduces debris holding areas. Because the powerful side-by-side two stage cylinders are in the closed position during transport, the cylinder piston rods are protected.



Tie Downs

Two-way tie downs (with optional stake pockets below) on all main beams and 4-way slots in the 3/8" high-strength smooth steel approach plate provide almost limitless tie down options. The deck is double-screwed not exceeding 32" on center to prevent cupping.

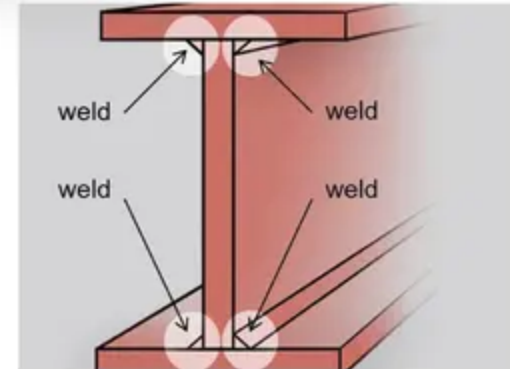

One-Piece Construction

I-beams are constructed of on-piece web and flange material and welded on all 4 sides to seal and protect the seams from rust. The entire trailer is primed and painted before decking and air, hydraulic and electrical lines are installed, for complete protection.



Full Width Greaseless Rollers

Axle tray front rollers span the full width of the beam. Less wear in undercarriage, less maintenance, and high reliability.



Grease Bank

Easy access grease points in the rear of the slide pan, as well as along the sides of the trailer, make greasing the entire trailer, including axle components and cylinder pivots, a simple, convenient process.



Galvanized Bumper Assembly

Corrosion-resistant bumper provides under-ride protection in transport position. Bumper travels with wheel area as it is positioned to allow the deck to be lowered to a 7 degree loading position.

RUGGED, DEPENDABLE, NOW THE FASTEST IN THE INDUSTRY

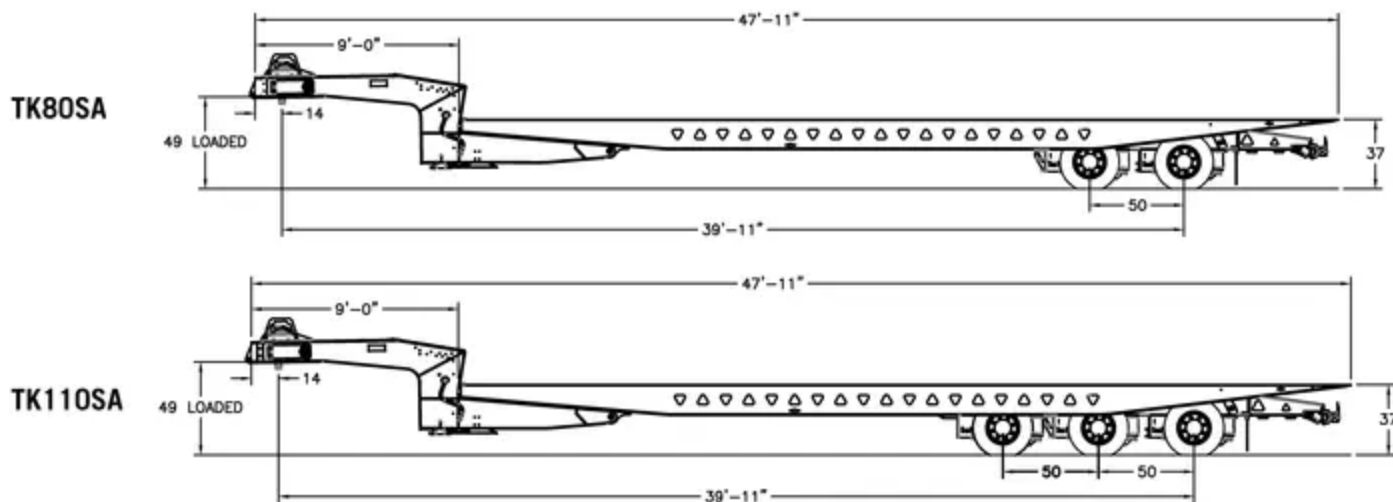

TKSA SPECIFICATIONS	TK80SA	TK110SA
Capacity	80K lbs uniform 50K lbs in 10 ft.	110K lbs uniform 70K lbs in 10 ft
3" I-beam cross members	12" on center (8" optional)	8" on center
25,000 lbs. axels (5/8" wall)	2 or 3	3

TKSA STANDARD EQUIPMENT On All Models:

- Perimeter frame gooseneck design
- 102" wide
- 37" loaded deck height with 17.5 tires
- 42" loaded deck height with 22.5 tires
- 49" loaded 5th wheel height
- 47'11" overall length is standard with other lengths available: 49'11" - 50'11" - 52'11"
- 9' upper deck
- 14" kingpin setting with 86" swing clearance
- Hydraulic sliding axles
- Tilting main deck - forms a ramp to upper deck
- 7 degree loading angle, 15 degree dump angle
- Air ride suspension
- Air ride raising/lowering control panel w/liquid filled air gauge on upper deck
- No traveling hydraulic lines for sliding axle operation
- Side by side 2-stage cylinder, closed in travel position
- Updated high-speed hydraulic system
- Greaseless composite bushing for rollers in the slide pan
- Air & electrical lines contained in protective track
- Single recessed winch roller at front of deck
- Skid plate on slope of upper deck
- 4S2M anti-lock brake system
- Dual push/pull style lighted hydraulic valve controls with Kar-Tech remote (winch only)
- 3rd taillight package (optional strobe in lieu of 3rd taillight)
- Central located lube system for axles
- 4 beam main frame construction
- Triangle cutouts
- 50" axle spacing
- Automatic slack adjusters
- One-piece oil seals
- Zip Tork axle nuts
- 80' winch cable with locking safety hook
- Combination key hole/stake pocket slots on approx 24" centers in inner and outer beams
- 3/8" high-strength smooth approach plate
- 2 side access tool boxes at front of upper deck
- Lighted hydraulic control panel
- LED lights, 50 state legal
- Electrical system per DOT regulations
- Mid-turn signal clearance lights
- Rubber mounted sealed lights with sealed harness system
- Mud Flaps
- Red & white conspicuity markings
- Zinc-rich primer and polyurethane topcoat

PROTECT YOUR INVESTMENT COMPREHENSIVE SUPPORT UNMATCHED SERVICE



From financing a trailer, to a complete refurbishment at our Factory Service Center, Trail King is there to keep your team hauling, day in and day out. Our trusted network of dealers and certified experts are ready to assist you.

△ PARTS

KEEP YOUR TEAM HAULING. Instantly access over 10,000 on-hand parts and a variety of online tools. All Trail King Certified dealers, fleets, and service facilities can place same-day shipping orders for convenient and efficient ordering. Customers looking for more information can contact a local Trail King dealer or submit direct inquiries to parts@trailking.com.

△ REFURB

PROTECT YOUR INVESTMENT. Extend the life of your trailer and increase future resale value by restoring it through Trail King's factory refurbishment program. Customers can request a free estimate for comprehensive refurbishments or specified repairs by visiting trailking.com/refurb-service. Our expert technicians specialize in Trail King equipment, but we also welcome other trailer brands.

△ FINANCE

100% EQUIPMENT FINANCING! Competitive rates and flexible terms are designed to make a Trail King purchase affordable, convenient, and secure. Trail King's innovative payment program operates with an understanding of the changing demands businesses face. Our full suite of financing structures, including Loans, Finance Leases, and TRAC Leases, makes it easier than ever before to own a Trail King trailer.

TRAIL KING IS BUILDING SUCCESS.

Trail King Industries, Inc., headquartered in Mitchell, SD, is the leading manufacturer of open deck and materials hauling trailers for the asphalt paving, construction, commercial hauling, agriculture, and specialized transport industries.

Over the years, Trail King has always kept one thing a top priority, our customers' success. Our trailers are customized for unique challenges and together we can create a solution that is just right for your team.

We don't just build trailers. We design hauling solutions.



trailking.com / TKSA

300 East Norway Ave. Mitchell, SD 57301 | 800-843-3324 | trailking.com

© 2023 Trail King Industries. All rights reserved.