

 OPEN-DECK
CONSTRUCTION

ROLLBACK TRAILER



TKRB



TRAIL KING
DEPENDABLE PERFORMANCE. EVERY HAUL. EVERY DAY.



BUILT RIGHT. BUILT RUGGED.

DEPENDABLE PERFORMANCE.



STANDARD FEATURES



Adjustable Pintle Hitch

To accommodate a wide variety of towing vehicles, Trail King rollback trailers come with an adjustable 4-bolt pintle hitch.



Roller Track

The roller track allows the deck to roll back in a smooth, even motion with no binding — even when the deck is fully loaded.



Heavy Duty Jack

A 25,000-lb. single 2 stage heavy-duty drop-leg jack is standard equipment on all Trail King rollback models.



Adjustable Bed Lock

Bed lock mechanism keeps the deck from accidentally rolling back while in the transport position and, because it is adjustable, always ensures a snug, secure closure.



Toolbox

Covered, lockable toolbox is conveniently located at the front of the trailer and is large enough to store all your chains and tools.



Protected Electrical System

Trail King rollback trailers feature rubber grommets wherever wiring runs through the frame or cross members, and rubber-mounted, shock-proof, sealed lights for longer, trouble-free, low-maintenance performance life.

** SCU and winch options available*



Heavy Duty D-Rings

Trail King includes heavy-duty 6" drop forged D-rings as standard equipment — not optional, as is the case with many manufacturers — so your rollback trailer is ready to secure even the toughest of loads.



Safety Headboard

The 4" safety headboard provides an extra dimension of safety and load-hauling security.

Axles, Wheels, and Tires

Truck-type axles and wheels, oil seal hubs, and radial tires are standard. You get the right equipment for the job, less down time and maintenance, and a long service life.

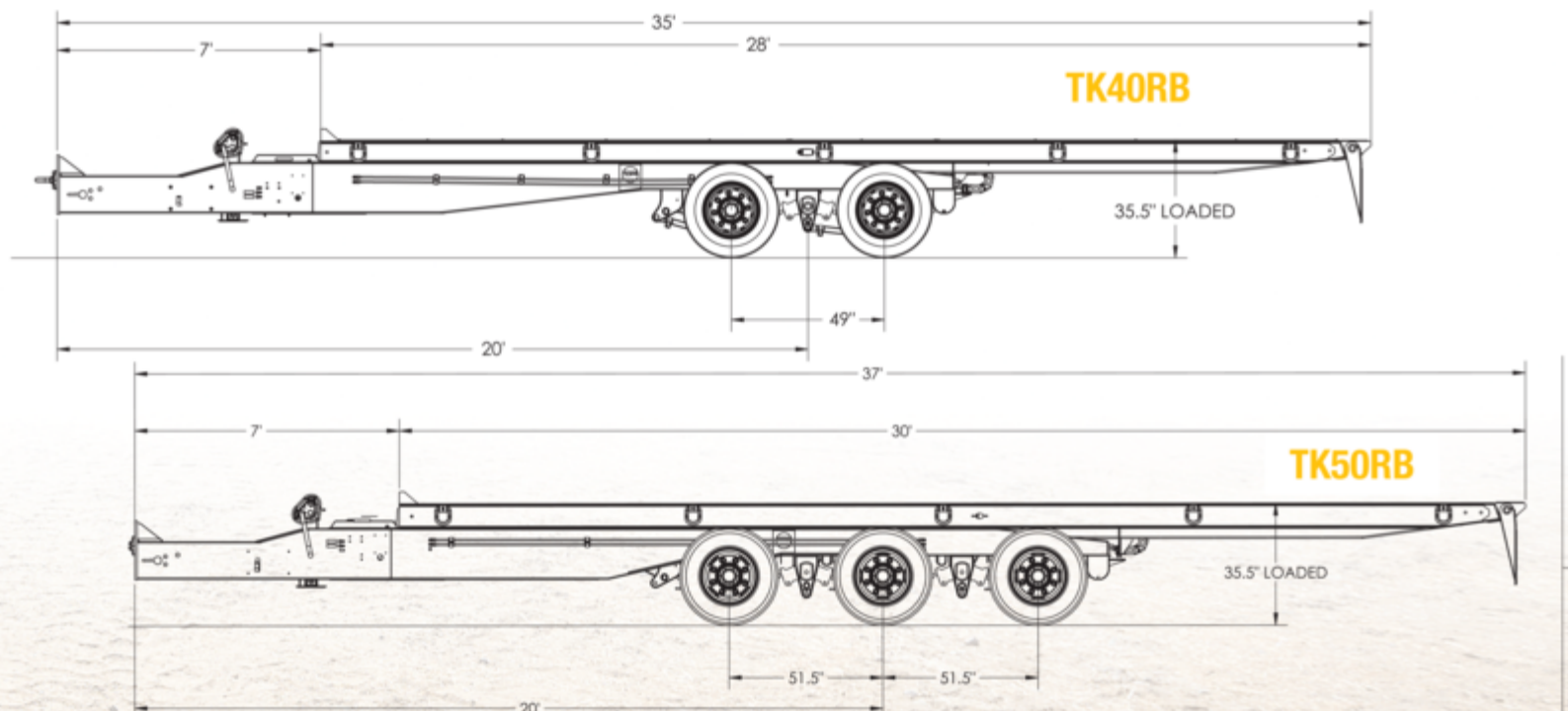

TKRB STANDARD EQUIPMENT	TK40RB	TK50RB
Capacity	40,000 lb.	50,000 lb.
Tongue Length	7'	7'
Deck Width	102"	102"
Deck Length	28'	30'
Pintle Eye Hitch (Adjustable Height)	16.5" - 32"	16.5" - 32"
Loaded Deck Height	35.5"	35.5"
Floor plate on approach plate and fold under	X	X
17" hydraulic fold-down approach plate and underride protection	X	X
Air Brakes	12.25" x 7.5" 4S2M ABS	12.25" x 7.5" 4S2M ABS
Dual Steel Disc Wheels	6.75" x 17.5" dual steel 8-stud hub-piloted	6.75" x 17.5" dual steel 8-stud hub-piloted
Tires	215/75R x 17.5	215/75R x 17.5
Axles	(2) 20,000 lb. / 49" spacing	(3) 20,000 lb. / 51.5" spacing
Spring Suspension	X	X
Safety Chains with Grab Hooks	X	X
Covered Lockable Toolbox	X	X
(10) D-Rings	X	X
Bed Rolls Back and Tilts to Achieve 7 Degree Load Angle	X	X
Headboard	X	X
Registration Holder	X	X
LED Lights	X	X
Combination Midturn Signal/Center Marker Light	X	X
Rubber mounted sealed lights with sealed harness system	X	X
Electrical System per DOT Regulations	X	X
Mudflaps	X	X
Red and White Conspicuity Markings	X	X
Paint 2-part epoxy primer & paint	X	X

* To meet 1997 Federal requirements, Trail King offers two variations of the anti-lock braking system. The minimum 2S1M system is available, but Trail King recommends the 4S2M system.

Products shown may feature optional equipment. Available specifications are subject to change without notice.



BIG TRAILER ADVANTAGES. SMALLER SIZE.

Trail King's Rollback trailer is outfitted with the highest quality materials for increased durability and capacity.

The continuous I-beam mainframe and I-beam cross members provide load hauling strength. With a constant 7 degree load angle for the entire length of the trailer bed, the TKRB provides a stress-free, safe and convenient operation for loading equipment.

**Invest in a Trail King Rollback trailer
for dependable performance.
Every Haul. Every Day.**



Find your nearest rep: www.TrailKing.com/find-a-rep

PROTECT YOUR INVESTMENT COMPREHENSIVE SUPPORT UNMATCHED SERVICE



From financing a trailer, to a complete refurbishment at our Factory Service Center, Trail King is there to keep your team hauling, day in and day out. Our trusted network of dealers and certified experts are ready to assist you.

△ PARTS

KEEP YOUR TEAM HAULING. Instantly access over 10,000 on-hand parts and a variety of online tools. All Trail King Certified dealers, fleets, and service facilities can place same-day shipping orders for convenient and efficient ordering. Customers looking for more information can contact a local Trail King dealer or submit direct inquiries to parts@trailking.com.

△ REFURB

PROTECT YOUR INVESTMENT. Extend the life of your trailer and increase future resale value by restoring it through Trail King's factory refurbishment program. Customers can request a free estimate for comprehensive refurbishments or specified repairs by visiting trailking.com/refurb-service. Our expert technicians specialize in Trail King equipment, but we also welcome other trailer brands.

△ FINANCE

100% EQUIPMENT FINANCING! Competitive rates and flexible terms are designed to make a Trail King purchase affordable, convenient, and secure. Trail King's innovative payment program operates with an understanding of the changing demands businesses face. Our full suite of financing structures, including Loans, Finance Leases, and TRAC Leases, makes it easier than ever before to own a Trail King trailer.

TRAIL KING IS BUILDING SUCCESS.

Trail King Industries, Inc., headquartered in Mitchell, SD, is the leading manufacturer of open deck and materials hauling trailers for the asphalt paving, construction, commercial hauling, agriculture, and specialized transport industries.

Over the years, Trail King has always kept one thing a top priority, our customers' success. Our trailers are customized for unique challenges and together we can create a solution that is just right for your team.

We don't just build trailers. We design hauling solutions.



TrailKing.com/TKRB



300 East Norway Ave. Mitchell, SD 57301 | 800-843-3324 | trailking.com

© 2020 Trail King Industries. All rights reserved.